

MM 1

Condenser Measurement Microphone

Order # 730.289



FEATURES

- Ideal for acoustic measurement in different environments
- Linear frequency response at 90° (diffuse field calibrated)
- Low tolerance ± 1.5 dB in the range between 50 Hz to 16,000 Hz
- Individual calibration data for 0° and 90° free-field measurement available upon request
- Simple calibration of several loudspeakers in the (home) studio
- Slim housing with protruding microphone capsule for minimum influence on the acoustic environment
- Handcrafted in Germany

APPLICATIONS

The MM 1 has been developed for the calibration of studio rooms, PA and ELA systems. In conjunction with a spectrum analyser, the sound pressure levels of loudspeakers can be checked in addition to frequency response measurements. Due to the slim housing with the protruding microphone capsule, the influence on the sound field is very low, so that a pressure build-up at high frequencies is mostly avoided.

The transmission pattern is selected so that an exactly linear frequency response is achieved with diffuse sound input. This makes the calibration of several loudspeakers in the studio particularly easy and fast.

The MM 1 also provides valuable services when investigating sound signals in research, development and industry.

TECHNICAL SPECIFICATIONS

Transducer type	Condenser (back electret)
Operating principle	Pressure
Frequency response	20 - 20,000 Hz (50 - 16,000 Hz ± 1.5 dB), diffuse field calibrated
Polar pattern	Omnidirectional
Sensitivity (0 dB = 1 V/Pa)	15 mV/Pa (= -36.5 dBV) ± 1 dB
Nominal impedance	160 Ω
Nominal load impedance	≥ 2.2 k Ω
Max. SPL at f = 1 kHz, k = 1%, $R_L = 2.2$ k Ω	122 dB SPL
Signal-to-noise ratio rel. to 1 Pa	> 57 dB
A-weighted equivalent SPL	approx. 26 dB(A)
Power supply	12 - 48 V phantom supply
Current consumption	approx. 1.9 mA
Output	electronically balanced
Connection	3-pin XLR, male
Dimensions:	
Length	139 mm
Shaft diameter	19 mm
Head diameter	9 mm
Weight	73 g

SUPPLIED ACCESSORY

MA-CL 21 Microphone clamp. Order # 727.946

OPTIONAL ACCESSORY

WS 10 Wind shield, charcoal grey. Order # 403.008

CREATE THE AMAZING



MM 1

Condenser Measurement Microphone

Order # 730.289

FREQUENCY RESPONSE & POLAR PATTERN

The displayed frequency response curve and polar pattern correspond to a typical production sample for this microphone. Each microphone comes with an individual 0° frequency response. The individual compensation curves for 0° and 90° free-field measurement can be requested via the following link: www.beyerdynamic.com/mm1-register

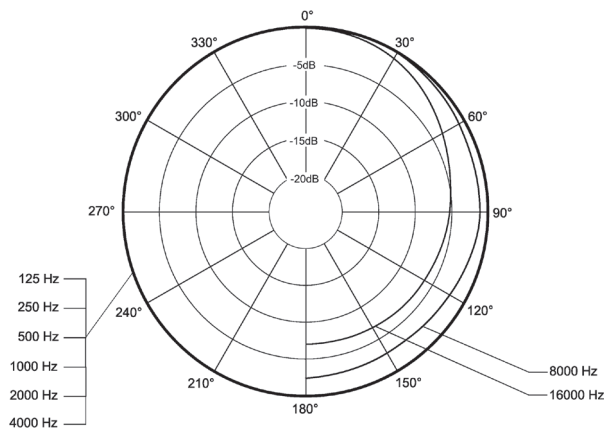
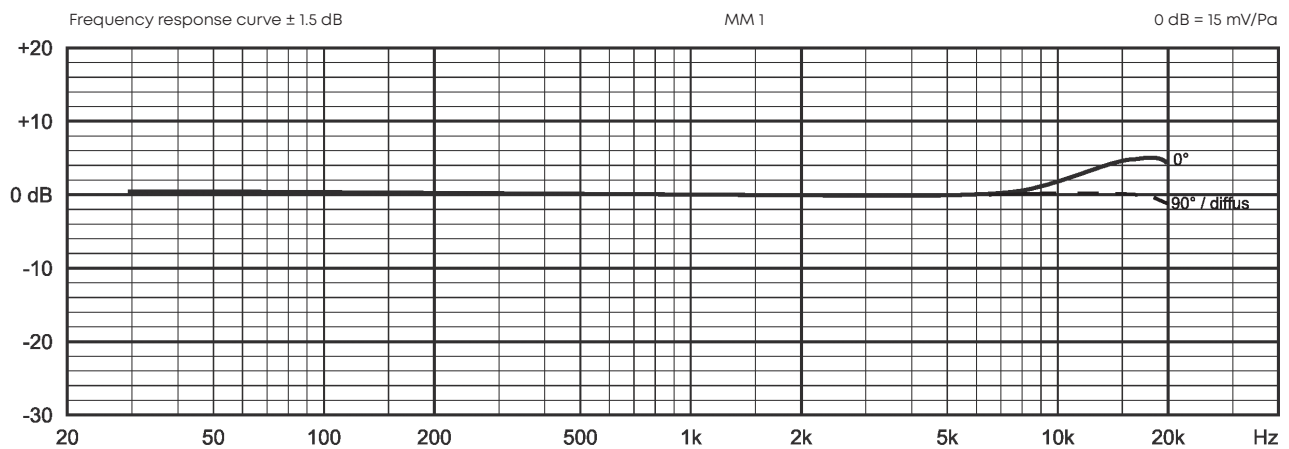

CREATE THE AMAZING



beyerdynamic GmbH & Co. KG
Theresienstr. 8 · 74072 Heilbronn / Germany
Tel. +49 (0) 71 31 / 617 - 300 · info@beyerdynamic.de · www.beyerdynamic.com

2/2

For further distributors worldwide, please go to www.beyerdynamic.com
Non-contractual illustrations. Contents subject to change without notice. E8/MM 1 (09.23)